

4	3	2	1
REV	DRWN	CHKD	DATE
			DESCRIPTION

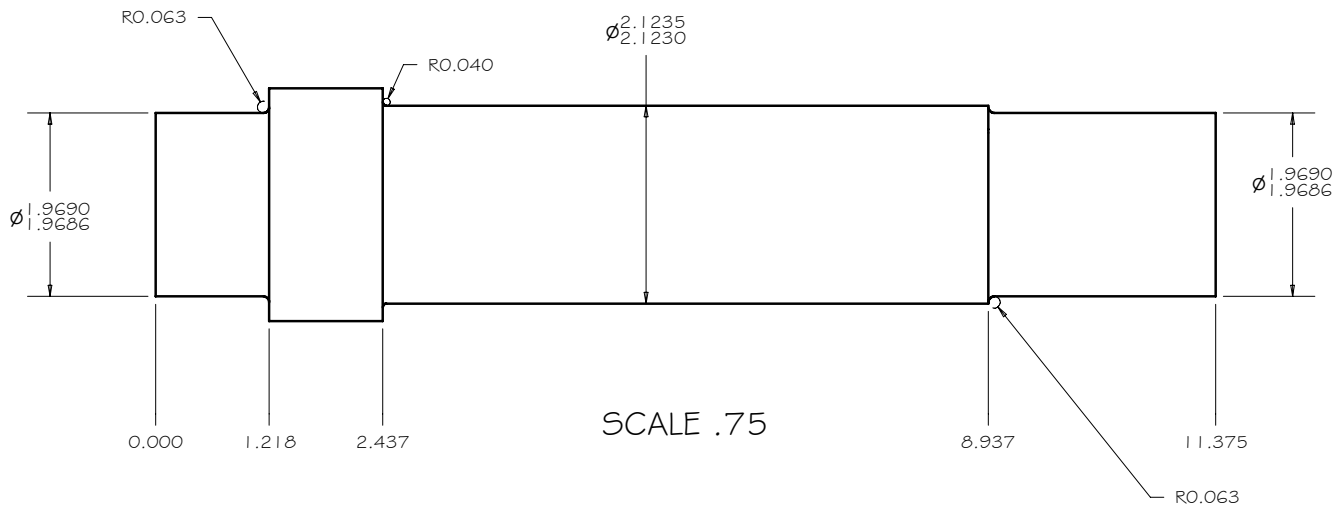
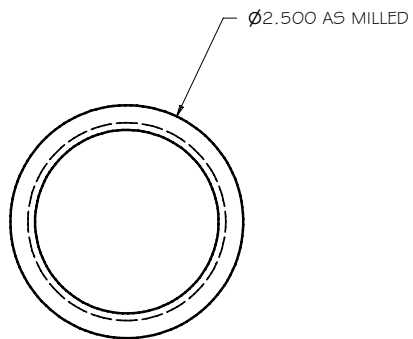

MATERIAL: 4340 COND A
ROUGH MACHINE
HEAT TREAT TO R/C 38-42
FINISH MACHINE

TOLERANCES UNLESS OTHERWISE NOTED: FRACTIONAL: 0"-6": ±1/64" 6"-24": ±1/32" 24": ±1/16" DECIMAL: X.X: ±0.1000" X.XX: ±0.0100" X.XXX: ±0.0050" X.XXXX: ±0.0001" ANGLES: ±0.5° FINISH: 125 MICRO INCHES BREAK ALL SHARP EDGES & CORNERS 1/64" MAX			DRAWN: vernon CHECKED: 2/20/2007 DESIGNED: vernon ENGINEER: vernon	PROJECT CODE: PD1G DWG NO: PD31	TITLE: MOUNT HAMILTON SUPPORT 120° DOME PD31 AXLE	NET A 1/1
MATERIAL:	FINISH:		PROJECT CODE: PD1G DWG NO: PD31			

4

3

2

1

4

3

2

1

B

B

A

A